

# Tiltrotator



EC20

Adaptable to all excavators in the weight class 16–22 tonnes

The **EC20** fits all machines in the weight class 16–22 tonnes.

**Tiltrotator:** Delivered complete with tube, quick hitches and electrical installation equipment for one machine. The mountings are adaptable to most machines.

**Electrical system:** Adaptable to 12- or 24-volt electrical systems.

- **Rotation**  $\infty$
- **$\pm 40^\circ$  tilt**
- **Complies with European safety standards**
- **Extra outlet with high-flow as standard, or double extra outlets. (Does not apply to models with grab.)**

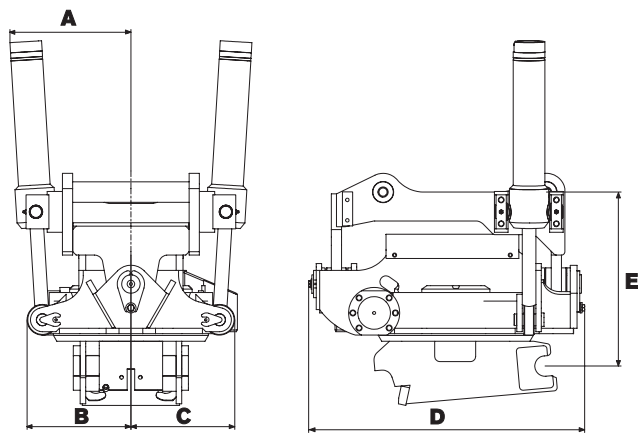

## Specifications, EC 20

Width <b>A</b> : (mm)	360
Width <b>B</b> : (mm)	310
Width <b>C</b> : (mm)	310
Total length <b>D</b> : (mm)	810
Construction height <b>E</b> : (mm)	510
Weight: (kg)	from 450
Tilt range:	$2 \times 40^\circ$
Flow requirement: (l/min)	40–80
Working pressure: (MPa)	18–21
Standard mountings:	S60, S1
Max. bucket width recommended by engcon: (mm)	1700
Max. breaking force: (kNm)	180

engcon reserves the right to modify designs without prior notice.